

The **Model WCM 7300** is designed to provide the highest possible sensitivity, resolution, and accuracy for water content determination in crude oil, other hydrocarbons, or other low dielectric liquids from a max of 25% to levels below 1000 parts per million (ppm). In oil and natural gas (condensate) production, water cut and S&W measurements are significantly improved with the WCM 7300 technology. Enhanced digital signal processing and full product temperature compensation are two of the technological advancements utilized by this device. Probe sizes from 2" through 12" are available. 4-20 mA and 0-5 volt outputs are available for remote readout. Water cut, process temperature or probe electrical value can be selected for viewing without removing conduit cover by use of a supplied magnet to operate an internal reed switch.

Product Temperature Compensation

The base dielectric constant (Dk) of oils can change with changes in temperature. This can cause traditional monitors to change without a variance in water content. For example; for a 10°F change, a typical crude oil may show a reading shift of as much as 0.1%, which normally would be considered as water. The WCM 7300 measures product temperature and calculates a corrected cut reading, providing a true water or S&W cut at any temperature up to 160°F.

Features

- **NACE Adaptable** - Can be modified for use in sour service.

Applications

LACT (Lease Automatic Custody Transfer) Units

Detect and provide relay contact closure that can be used to reroute oil that has excess S&W.

Pipeline Loading

Monitor transfer of petroleum/condensate products from loading facilities.

Dehydration Equipment

Determine and enhance equipment efficiencies, by monitoring the product and indicating water content.

Fuel Oil Monitoring

Determine contamination of fuel oil by condensation, or other external factors, before entry to engine.

Storage and Treating Facilities

Monitoring and early detection of undesirable conditions as well as interface detection during de-watering of storage tanks.

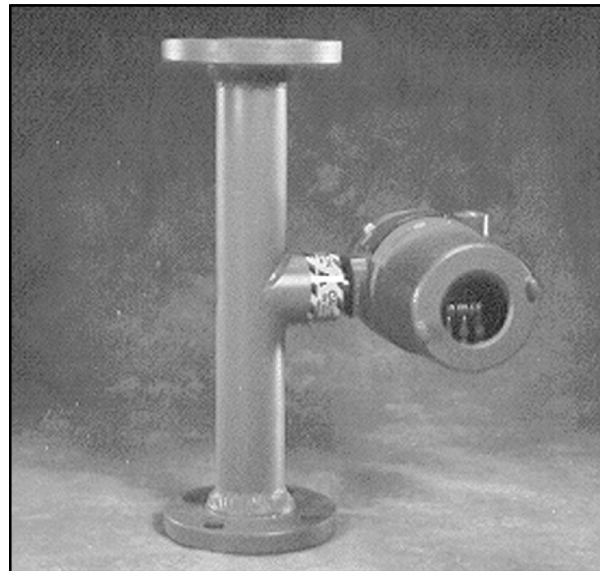

WCM 7300 Water Cut Monitor

Measurement/Monitor Specifications

Power Supply

20-30 Vdc +/-10% @ nominal, 100 mA max.

S&W Full Scale Range

0-25%

Field adjustable to 0-5%, 0-10%, etc.

Accuracy

Is defined as the variance observed between the 7300 reading and the water grindout of the oil.

Normal variances are:

+/- .05 from 0 to 5% water

+/- .1 from 5 to 10% water

+/- .15 from 10% to 15% water

+/- .2 to .25 from 15 to 25% water

Displays

One line 16 character, alphanumeric LCD showing by selection:

Water Cut

Process Temperature

Probe Electrical Value

Red/Green LED showing good oil, bad oil, or by passing, condition.

Pressure Ratings

As per Flange selection, 1440 psig max. (Others by special order)

NPT - 1440 psig max.

Victualic grooved - 350 psig

WCM 7300 Dimensions

Inches (mm)

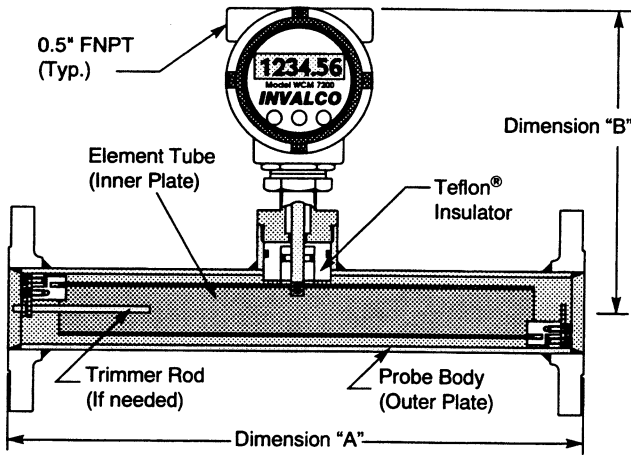

Size	Dimension "A"	Dimension "B"	Approx. Weight (lbs)
2 inch	17.0" (431)	8.6" (218)	20
3 inch	32.0" (811)	9.0" (228)	45
4 inch	32.0" (811)	9.5" (241)	72
6 inch	32.0" (811)	10.5" (266)	127
8 inch	32.0" (811)	11.5" (291)	190
10 inch	32.0" (811)	12.6" (319)	268
12 inch +	Consult Factory		

Note: Dimensions - Inches to the nearest tenth (millimeters to the nearest whole mm), each independently dimensioned from respective engineering drawings.

WCM 7300 Probe/Monitor Assemblies Ordering Information

WCM 7300	WATER CUT MONITOR, DIGITAL, TEMPERATURE COMPENSATING, Ranges from 0-20% water		
	PROBE MATERIAL: Carbon Steel		
	CODE	PROBE BODY SIZE	
	2	2 INCH I.D. x 17" FACE TO FACE	
	3	3 INCH I.D. x 32" FACE TO FACE	
	4	4 INCH I.D. x 32" FACE TO FACE	
	6	6 INCH I.D. x 32" FACE TO FACE	
	8	8 INCH I.D. x 32" FACE TO FACE	
	CODE	END CONNECTIONS	
	00	SCREWED ENDS (to 3" only)	
	00	GROOVED ENDS/Victaulic (to 4" only)	
	00	150 LB ANSI RAISED FACE	
	30	300 LB ANSI RAISED FACE	
	60	600 LB ANSI RAISED FACE (SCH 80) (FOR 8" AND 10")	
	90	900 LB ANSI RAISED FACE and RING JOINT (SCH 160) (FOR 10")	
	05	150 LB ANSI RTJ	
	35	300 LB ANSI RTJ	
	65	600 LB ANSI RTJ (SCH 80) (FOR 8" AND 10")	
	95	900 LB ANSI RTJ (SCH 80)	
	115	1500 LB ANSI RTJ (SCH 160)	
	CODE	MATERIAL AND TEMPERATURE OPTIONS	
	B	STANDARD MATERIALS, A53B CARBON STEEL, -20-160F	
	H	STANDARD MATERIALS/HIGH TEMP, -20 - 375F 1	
	S	316 STAINLESS STEEL MATERIALS -20-160F	
	T	316 STAINLESS STEEL/HIGH TEMP, -20 - 375F 1	
	CODE	CONNECTION STYLE	
	S	SCREWED CONNECTIONS, MNPT	
	G	VICTAULIC CONNECTIONS (GROOVED)	
	F	FLANGED CONNECTIONS	
	CODE	OPEN	
	P	Epoxy	
Example:	4	60	B F P = WCM7300 - 460 - BFP
Choose one code selection from each option group to build model number and correct pricing.			

Notes:

1 - Consult factory for temperature compensation



www.fmcinvalco.com

The specifications contained herein are subject to change without notice and any user of said specifications should verify from the manufacturer that the specifications are currently in effect. Otherwise, the manufacturer assumes no responsibility for the use of specifications which may have been changed and are no longer in effect.